

Standby Power Rating

35 kW 60 Hz

Liquid Cooled
Gas Engine
Generator Sets

Model Numbers:

05259 (Tan - Steel)

05259T (Tan - Steel)

05260 (Gray - Aluminum)

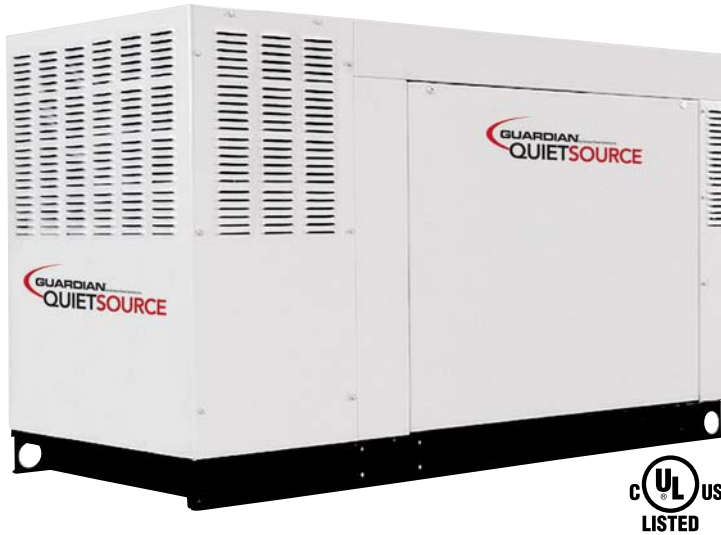

Whisper-Test™

Low Noise Exercise
- 63 dB(A) at 23 feet

UL 2200 Listed

Power Matched

GENERAC 2.4L ENGINE

Naturally Aspirated

2 Year Limited Warranty

Model 5259T is equipped with a
200 amp NEMA 3R Transfer Switch.
Transfer Switches are available for
Models 5259 and 5260.

STANDARD EQUIPMENT

- All input connections in one single area
- High coolant temperature shutdown
- Low oil pressure shutdown
- Low coolant level automatic shutdown
- Overspeed automatic shutdown
- Crank timer
- Exercise timer
- Oil drain extension
- Cool flow radiator
- Closed coolant recovery system
- Watertight state of the art electrical connectors
- Mainline circuit breaker
- Radiator drain extension
- Battery charge alternator
- 2 Amp static battery charger
- Battery cables
- Battery rack
- Fan and belt guards
- Isochronous governor
- UV/Ozone resistant hoses

FEATURES

- Innovative design and fully prototype tested
- UL2200 Listed
- Solid state frequency compensated voltage regulator
- Dynamic and static battery charger
- Sound attenuated acoustically designed enclosure
- Whisper-Test™ Mode for low noise level exercise
- Acoustically designed engine cooling system
- High flow low noise factory engineered exhaust system
- State of the art R100 digital control system
- Watertight electrical connectors
- Rodent proof construction
- High efficiency, low distortion Generac designed alternator
- Vibration isolated from mounting base
- Matching Generac transfer switches engineered and tested to work as a system
- All components easily accessible for maintenance
- Electrostatically applied powder paint

GUARDIAN by Generac Power Systems, Inc.
QUIETSOURCE™

APPLICATION & ENGINEERING DATA

STANDBY 35 kW



GENERATOR SPECIFICATIONS

TYPE.....	Synchronous
ROTOR INSULATION.....	Class H
STATOR INSULATION.....	Class H
TOTAL HARMONIC DISTORTION.....	<5%
TELEPHONE INTERFERENCE FACTOR (TIF).....	<50
ALTERNATOR OUTPUT LEADS 3 PHASE.....	4 wire
BEARINGS.....	Sealed Ball
COUPLING.....	Flexible Disc
LOAD CAPACITY (STANDBY RATING).....	35 kW
EXCITATION SYSTEM.....	Direct

NOTE: Generator rating and performance in accordance with ISO8528-5, BS5514, SAE J1349, ISO3046, and DIN6271 standards.

VOLTAGE REGULATOR

TYPE.....	Electronic
SENSING.....	Single Phase
REGULATION.....	± 1%
FEATURES.....	V/F Adjustable Adjustable Voltage and Gain LED Indicators

GENERATOR FEATURES

- Revolving field heavy duty generator
- Directly connected to the engine
- Operating temperature rise 120 °C above a 40 °C ambient
- Insulation is Class H rated at 150 °C rise
- All models are fully prototyped tested

CONTROL PANEL FEATURES

- | | |
|--|---|
| <input type="checkbox"/> SEVEN LED INDICATOR LIGHTS <ul style="list-style-type: none">• System ready• Low fuel pressure• Low battery• Low oil pressure• High coolant temp/low coolant temp• Overspeed• Overcrank | <input type="checkbox"/> ADDITIONAL FUNCTIONS <ul style="list-style-type: none">• Utility sensing• Delay on utility failure for engine start• Engine warm-up before transfer• Delay to retransfer to utility• Engine cooldown timer• Exerciser not set |
|--|---|
- INTERNAL FUNCTIONS:
- 3 position switch (auto, off and manual)
 - 2 wire start for any transfer switch
 - Communicates with the Generac RTS transfer switch
 - Built-in 7 day exerciser
 - Selectable engine speed at exercise
 - Governor controller is built into the master control board
 - Temperature range -40 °C to 70 °C

ENGINE SPECIFICATIONS

MAKE.....	Generac
MODEL.....	Inline 4
CYLINDERS.....	4
DISPLACEMENT.....	2.4 Liter, 146 cu. in.
BORE.....	3.41
STROKE.....	3.94
COMPRESSION RATIO.....	8.5:1
INTAKE AIR SYSTEM.....	Naturally Aspirated
VALVE SEATS.....	Hardened
LIFTER TYPE.....	Hydraulic

GOVERNOR SPECIFICATIONS

TYPE.....	Electronic
FREQUENCY REGULATION.....	Isochronous
STEADY STATE REGULATION.....	± 0.25
ADJUSTMENTS FOR:	
Speed.....	Yes
Droop.....	Yes

ENGINE LUBRICATION SYSTEM

OIL PUMP.....	Gear
OIL FILTER.....	Full flow spin-on cartridge
CRANKCASE CAPACITY.....	4 Quarts

ENGINE COOLING SYSTEM

TYPE.....	Closed
WATER PUMP.....	Belt driven
FAN SPEED.....	2150
FAN DIAMETER.....	18 inches
FAN MODE.....	Pusher

FUEL SYSTEM

FUEL TYPE.....	Natural gas, propane vapor
CARBURETOR.....	Down Draft
SECONDARY FUEL REGULATOR.....	Standard
FUEL SHUT OFF SOLENOID.....	Standard
OPERATING FUEL PRESSURE.....	5" - 14" H ₂ O

ELECTRICAL SYSTEM

BATTERY CHARGE ALTERNATOR.....	12V 30 Amp
STATIC BATTERY CHARGER.....	2 Amp
RECOMMENDED BATTERY.....	Group 26, 525CCA
SYSTEM VOLTAGE.....	12 Volts

OPERATING DATA

		STANDBY 35		
KW RATING		35		
ENGINE SIZE		2.4 Liter 4 cyl.		
GENERATOR OUTPUT VOLTAGE/KW - 60Hz 120/240V, 1-phase, 1.0 pf LP and NG		KW 35	AMP 146	CB Size 175
GENERATOR LOCKED ROTOR KVA AVAILABLE @ VOLTAGE DIP OF 35% Single phase		69		
ENGINE FUEL CONSUMPTION (Natural Gas) (Propane)		Natural Gas (ft ³ /hr.)	Propane (gal/hr.)	cu ft/hr
Exercise cycle		87	95	34.5
25% of rated load		150	1.64	59.6
50% of rated load		291	3.18	115.7
75% of rated load		405	4.42	160.8
100% of rated load		560	6.11	222.3
ENGINE COOLING				
Air flow (inlet air including alternator and combustion air)	ft ³ /min.	2,460		
System coolant capacity	US gal.	2.5		
Heat rejection to coolant	BTU/hr.	134,000		
Max. operating air temp. on radiator	°C (°F)	60 (150)		
Max. ambient temperature	°C (°F)	50 (140)		
COMBUSTION AIR REQUIREMENTS				
Flow at rated power 60 Hz	cfm	129		
SOUND EMISSIONS IN DBA				
Exercising at 7 meters		63		
Full load at 7 meters		74		
EXHAUST				
Exhaust flow at rated output 60 Hz	cfm	360		
Exhaust temp. at muffler outlet	°F	1050		
ENGINE PARAMETERS				
Rated synchronous RPM	60 Hz	3600		
HP at rated KW	60 Hz	55		
POWER ADJUSTMENT FOR AMBIENT CONDITIONS				
Temperature Deration				
3% for every 10 °C above - °C		40		
1.65% for every 10 °F above - °F		104		
Altitude Deration				
1% for every 100 m above - m		915		
3% for every 1000 ft. above - ft.		3000		
TRANSFER SWITCH SPECIFICATIONS <i>If so equipped</i>				
No. of Poles		2		
Current Rating	(amps)	200		
Voltage Rating	(VAC)	250		
Utility Voltage Monitor	(fixed)			
	<i>Pick-up</i>	80%		
	<i>Dropout</i>	60%		
Enclosure - NEMA 3R		Standard		
Return to Utility		15 seconds		
Exerciser 15 minute weekly		Standard		
UL 1008 Listed		Standard		
Dimensions	(H" x W" x D")	20 x 15 x 7		
Weight		35 lbs.		

RATING: All single phase units are rated at 1.0 power factor. STANDBY RATING: Standby ratings apply to installations served by a reliable utility source. The standby rating is applicable to varying loads for the duration of a power outage. There is no overload capability for this rating. Ratings are in accordance with ISO-3046-1. Design and specifications are subject to change without notice. Maximum wattage and current are subject to and limited by such factors as fuel Btu content, ambient temperature, altitude, engine power and condition, etc.

INTERCONNECTIONS

STANDBY 35 kW

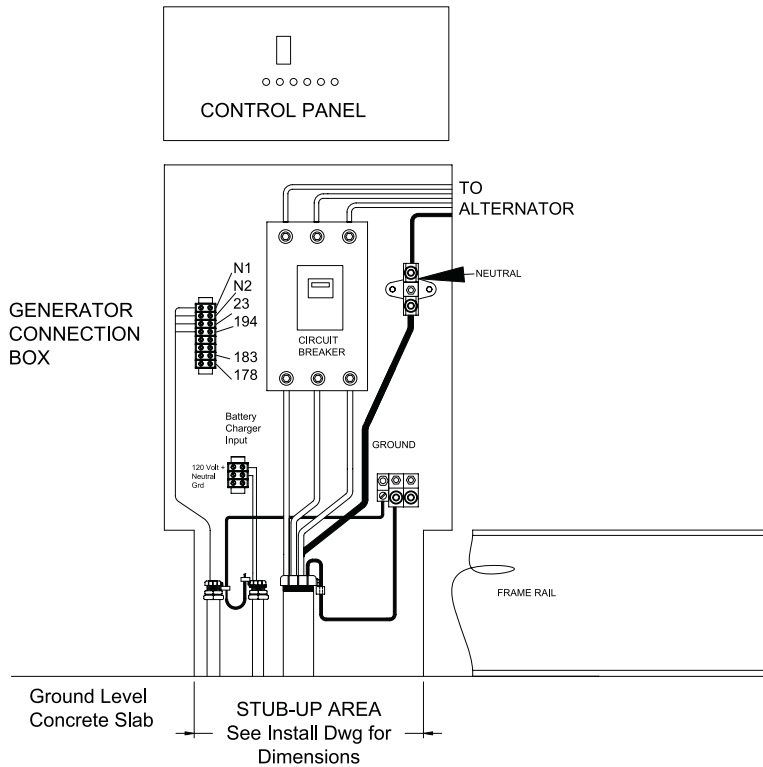

Installation Drawing Ref. No. OF6286

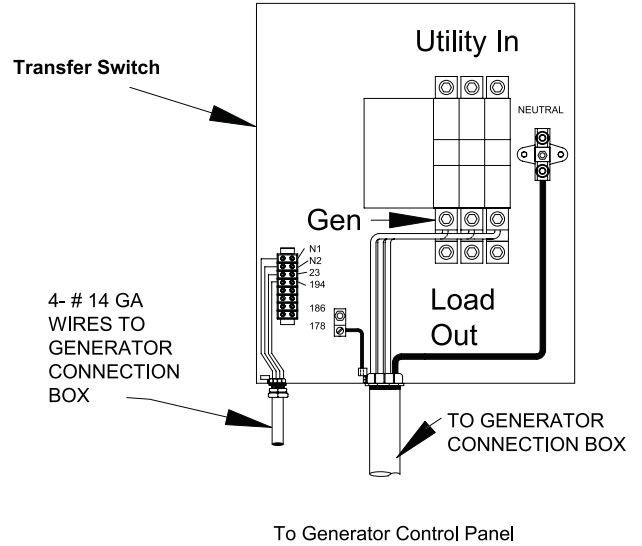

CIRCUIT BREAKER SIZE

KW	VOLTS	AMPS	LUG SIZE
35	240 1 Ø	175	#6 to 300 mcm

INSTALLATION LAYOUT

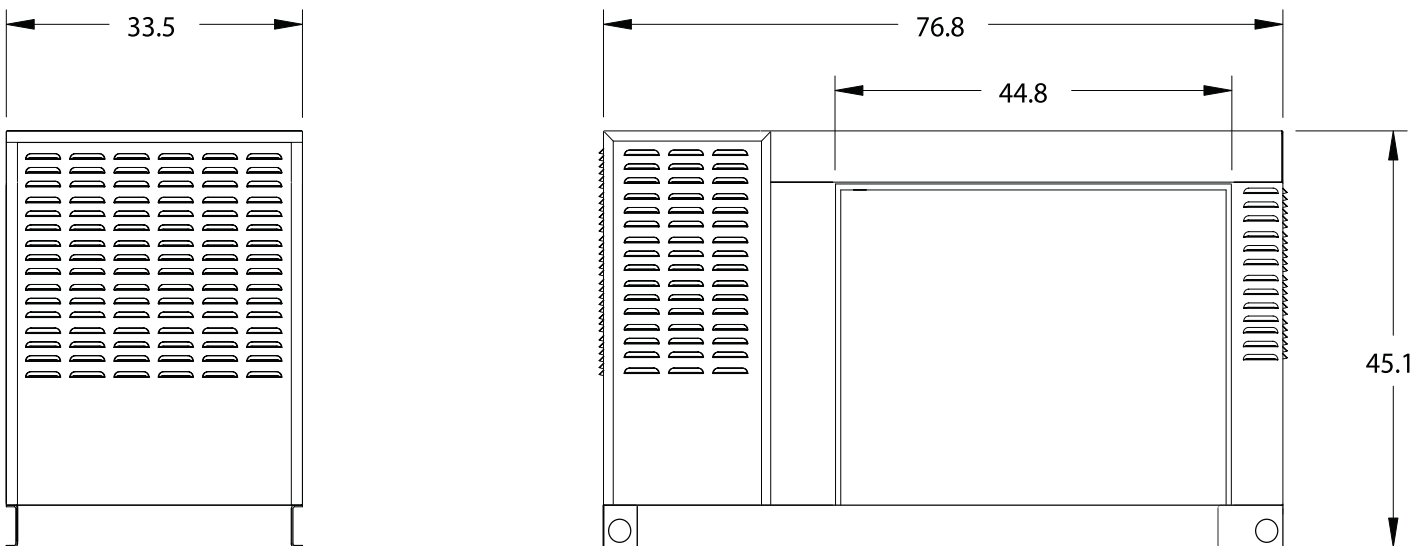

UNIT WEIGHT: Steel 1414 lbs.
Aluminum 1393 lbs.

GENERAC® POWER SYSTEMS, INC. • P.O. BOX 297 • WHITEWATER, WI 53190
www.guardiangenerators.com